



basic education

Department:
Basic Education
REPUBLIC OF SOUTH AFRICA

**NATIONAL
SENIOR CERTIFICATE**

GRADE 12

PHYSICAL SCIENCES: CHEMISTRY (P2)

FEBRUARY/MARCH 2012

MARKS: 150

TIME: 3 hours

This question paper consists of 16 pages and 4 data sheets.

INSTRUCTIONS AND INFORMATION

1. Write your centre number and examination number in the appropriate spaces on the ANSWER BOOK.
2. Answer ALL the questions in the ANSWER BOOK.
3. This question paper consists of TWO sections:

SECTION A (25)
SECTION B (125)
4. You may use a non-programmable calculator.
5. You may use appropriate mathematical instruments.
6. Number the answers correctly according to the numbering system used in this question paper.
7. Data sheets and a periodic table are attached for your use.
8. Give brief motivations, discussions, et cetera where required.
9. Round off your final numerical answers to a minimum of TWO decimal places.

SECTION A**QUESTION 1: ONE-WORD ITEMS**

Give ONE word/term for each of the following descriptions. Write only the word/term next to the question number (1.1–1.5) in the ANSWER BOOK.

- 1.1 An atom or a group of atoms that gives an organic compound its chemical properties (1)
- 1.2 The type of addition reaction in which a hydrogen halide is added to an alkene (1)
- 1.3 The minimum energy needed to start a reaction (1)
- 1.4 The component of a galvanic cell that allows for the movement of ions between the half-cells (1)
- 1.5 The type of cell that cannot be recharged (1)
- [5]**

QUESTION 2: MULTIPLE-CHOICE QUESTIONS

Four options are provided as possible answers to the following questions. Each question has only ONE correct answer. Write only the letter (A–D) next to the question number (2.1–2.10) in the ANSWER BOOK.

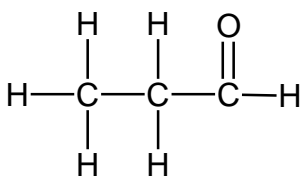
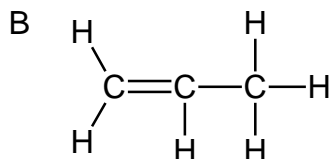
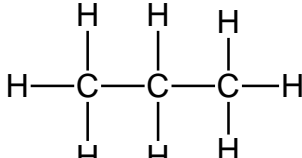
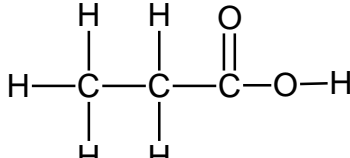
- 2.1 Which ONE of the following compounds CANNOT be an alkene?
- A C_2H_4
- B C_3H_6
- C C_3H_8
- D C_4H_8 (2)
- 2.2 Which ONE of the compounds represented below is an UNSATURATED hydrocarbon?
- A 
- B 
- C 
- D  (2)

2.3 Consider the two organic compounds represented by **I** and **II**, as shown below.

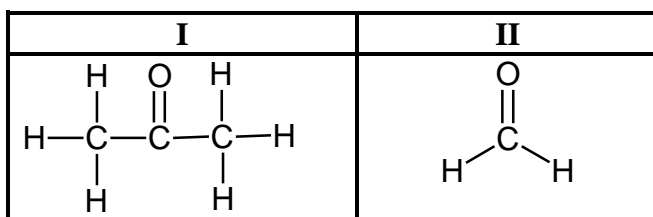

Which ONE of the following correctly represents the homologous series to which each belongs?

	I	II
A	aldehyde	alcohol
B	ketone	alcohol
C	ketone	aldehyde
D	aldehyde	ketone

(2)

2.4 Consider the chemical reaction represented by the equation below.



Which ONE of the following changes will increase the rate of production of $\text{CO}_2(\text{g})$?

- A Increase in pressure
- B Increase in mass of CaCO_3
- C Increase in volume of $\text{HCl}(\text{aq})$
- D Increase in concentration of $\text{HCl}(\text{aq})$

(2)

- 2.5 The diagram below shows the change in potential energy for a hypothetical reaction, represented by the following equation:

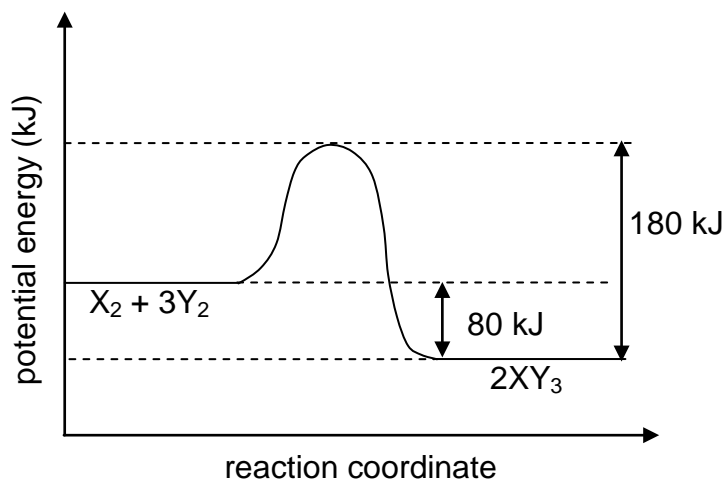
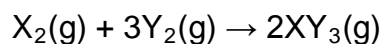

The activation energy for the forward reaction is ...

- A -80 kJ
- B 80 kJ
- C 100 kJ
- D 180 kJ

(2)

- 2.6 The following hypothetical reaction reaches equilibrium in a closed container at a certain temperature:



Which ONE of the following changes will increase the AMOUNT of XY(g)?

- A Decrease in temperature
- B Increase in temperature
- C Increase in pressure
- D Decrease in pressure

(2)

- 2.7 The gain of electrons by a substance in a chemical reaction is known as ...
- A oxidation.
 - B reduction.
 - C electrolysis.
 - D oxidation and reduction. (2)
- 2.8 Which ONE of the following statements regarding a copper-silver galvanic cell is TRUE?
- A Silver is formed at the anode.
 - B Copper is formed at the anode.
 - C Silver is formed at the cathode.
 - D Copper is formed at the cathode. (2)
- 2.9 Which ONE of the following substances can be used as an electrolyte?
- A Mercury
 - B Molten copper
 - C Sugar dissolved in distilled water
 - D Table salt dissolved in distilled water (2)
- 2.10 Which ONE of the following is NOT associated with eutrophication in water?
- A Dead zones
 - B Algal bloom
 - C Depletion of oxygen
 - D Increased aquatic life (2)

[20]**TOTAL SECTION A: 25**

SECTION B**INSTRUCTIONS**

1. Start EACH question on a NEW page.
2. Leave ONE line between two subquestions, for example between QUESTION 3.1 and QUESTION 3.2.
3. Show the formulae and substitutions in ALL calculations.
4. Round off your final numerical answers to a minimum of TWO decimal places.

QUESTION 3 (Start on a new page.)

Four compounds, labelled **A**, **B**, **C** and **D**, are shown below.

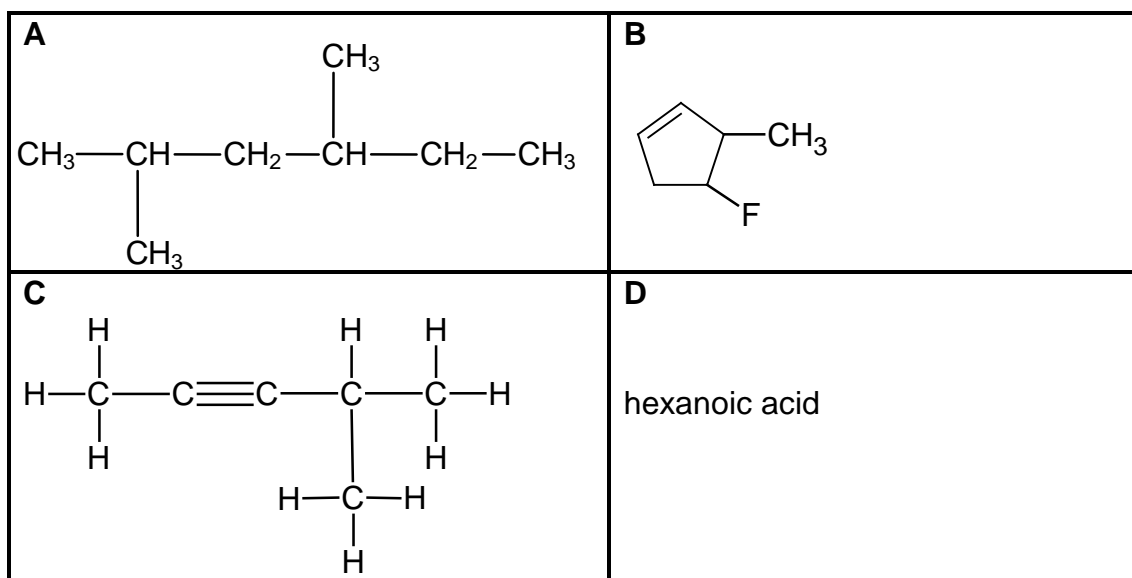

Write down the:

- 3.1 Homologous series to which compound **A** belongs (1)
 - 3.2 IUPAC name of compound **A** (2)
 - 3.3 IUPAC name of compound **B** (2)
 - 3.4 IUPAC name of compound **C** (2)
 - 3.5 Structural formula of compound **D** (2)
- [9]**

QUESTION 4 (Start on a new page.)

4.1 In the petroleum industry smaller, more useful hydrocarbons are obtained from larger ones by a process called cracking.

4.1.1 Define the term *hydrocarbon*. (2)

The compound $C_{10}H_{22}$ is cracked to obtain alkane **X** and another hydrocarbon. The cracking reaction is represented by the following incomplete equation:

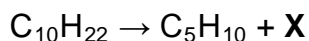

4.1.2 Write down the molecular formula of compound **X**. (1)

The cracking process requires very high temperatures. Therefore engineers use a catalyst in the reaction.

4.1.3 Give TWO reasons why they use a catalyst. (2)

2-methylbut-1-ene (C_5H_{10}) is one of the compounds formed in this reaction.

4.1.4 Write down the structural formula of 2-methylbut-1-ene. (2)

4.1.5 Name the type of reaction that occurs when 2-methylbut-1-ene reacts with hydrogen. (1)

4.2 Consider the structural isomers represented by **A**, **B** and **C** shown below.

	COMPOUND	BOILING POINT (°C)
A	$CH_3-CH_2-CH_2-CH_2-CH_3$	36
B	$ \begin{array}{c} CH_3-CH_2-CH-CH_3 \\ \\ CH_3 \end{array} $	28
C	$ \begin{array}{c} CH_3 \\ \\ CH_3-C-CH_3 \\ \\ CH_3 \end{array} $	9

4.2.1 Give a reason why the above compounds are considered to be structural isomers. (2)

4.2.2 Describe the trend in the boiling points from **A** to **C**, as shown in the table. Explain this trend by referring to molecular structure, intermolecular forces and energy involved. (4)

4.2.3 Give a reason why branched hydrocarbons are preferred to straight chain hydrocarbons as fuel. (2)

[16]

QUESTION 5 (Start on a new page.)

- 5.1 In the flow diagram below, **X**, **Y** and **Z** represent three different types of organic reactions. **P** represents an organic compound.

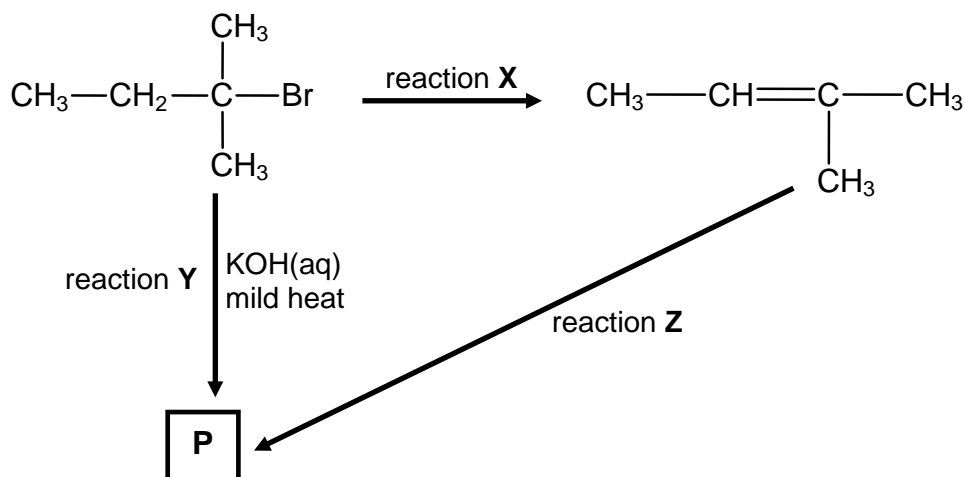

- 5.1.1 Name the type of reaction represented by **X**. (1)
- 5.1.2 State TWO reaction conditions needed for reaction **X**. (2)
- 5.1.3 Reaction **Y** represents a substitution reaction. Write down the structural formula of compound **P** formed in this reaction. (2)
- 5.1.4 Apart from the organic reactant, write down the NAME or FORMULA of the other reactant needed in reaction **Z**. (1)
- 5.1.5 Name the type of reaction represented by **Z**. (1)

- 5.2 Hexanoic acid is responsible for the unique odour associated with goats. When it reacts with alcohol **X**, ethyl hexanoate, which is used commercially as a fruit flavour, is formed.

Learners set up the apparatus shown below to prepare ethyl hexanoate in a laboratory.

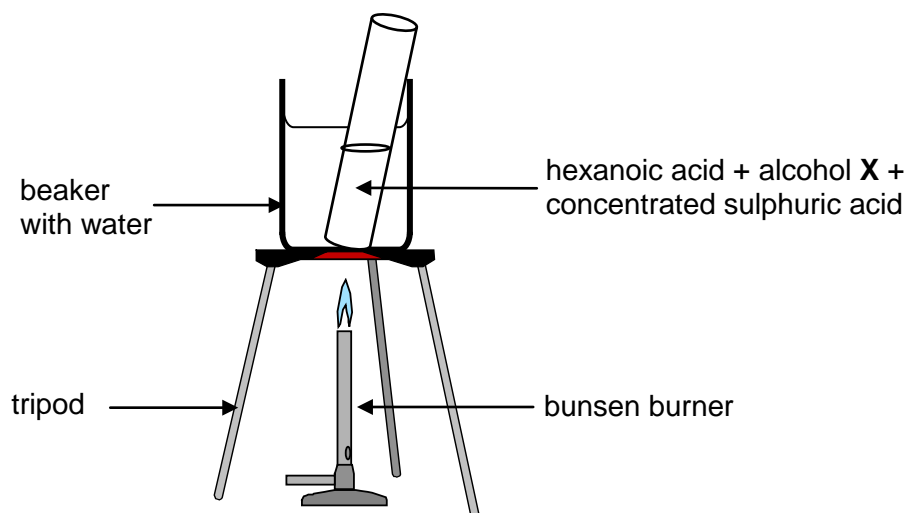

- 5.2.1 Write down the IUPAC name of alcohol **X**. (2)
- 5.2.2 What is the role of the sulphuric acid in the above reaction? (1)
- 5.2.3 Use structural formulae to write down a balanced equation for the preparation of ethyl hexanoate. (6)
- 5.2.4 Give a reason why the test tube and its contents are heated in a water bath and not directly over the flame. (1)
- 5.2.5 Write down ONE use of esters in the food manufacturing industry. (1)

[18]

QUESTION 6 (Start on a new page.)

A group of learners use the reaction between zinc and sulphuric acid to investigate one of the factors that affects reaction rate. The equation below represents the reaction that takes place.

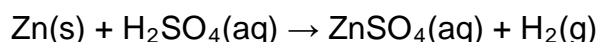

They add 6,5 g of zinc granules to excess DILUTE sulphuric acid and measure the mass of zinc used per unit time.

The learners then repeat the experiment using excess CONCENTRATED sulphuric acid.

- 6.1 Define the term *reaction rate*. (2)
- 6.2 Give a reason why the acid must be in excess. (1)
- 6.3 Write down a hypothesis for this investigation. (2)
- 6.4 Give a reason why the learners must use the same amount of ZINC GRANULES in both experiments. (1)

The results obtained for the reaction using DILUTE sulphuric acid are represented in the graph below.

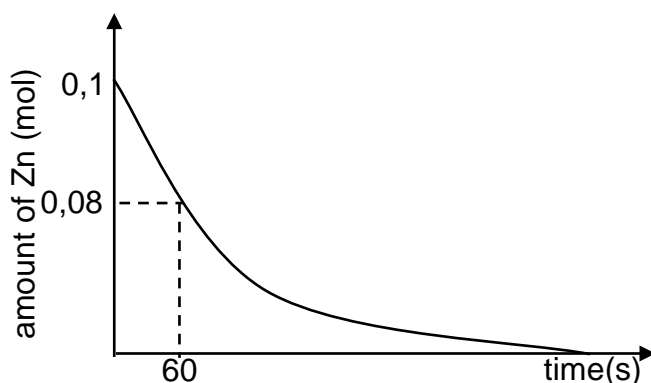

- 6.5 Using the graph, calculate the mass of zinc used from $t = 0$ s to $t = 60$ s. (4)
- 6.6 Calculate the average rate of the reaction (in gram per second) during the first 60 s. (2)
- 6.7 Copy the above graph into your ANSWER BOOK. ON THE SAME SET OF AXES, use a dotted line to show the curve that will be obtained when concentrated sulphuric acid is used. Label that curve **P** (no numerical values are required). (2)

[14]

QUESTION 7 (Start on a new page.)

The rapidly increasing human population is resulting in an ever-increasing demand for food. To meet this demand, farmers apply fertiliser to the same cultivated land EACH YEAR.

- 7.1 Explain why farmers have to apply fertilisers to their land EACH YEAR. (2)
- 7.2 Write down ONE negative impact that OVERFERTILISATION can have on humans. (2)
- 7.3 Sulphuric acid is an important substance used in the manufacture of fertilisers.

The equation below represents one of the steps in the industrial preparation of sulphuric acid.



- 7.3.1 Write down the name of the process used to prepare sulphuric acid in industry. (1)
- 7.3.2 Write down the NAME or FORMULA of the catalyst used in the process in QUESTION 7.3.1. (1)
- 7.3.3 Is the forward reaction exothermic or endothermic? Give a reason for the answer. (2)
- 7.3.4 Write down the NAME or FORMULA of the fertiliser formed when sulphuric acid reacts with ammonia. (2)

The reaction, represented by the equation in QUESTION 7.3, reaches equilibrium at a certain temperature in a 2 dm^3 closed container.

On analysis of the equilibrium mixture, it is found that 0,6 mole of $\text{SO}_2(\text{g})$, 0,5 mole of $\text{O}_2(\text{g})$ and 0,4 mole of $\text{SO}_3(\text{g})$ are present in the container.

- 7.3.5 List THREE changes that can be made to this equilibrium to increase the yield of $\text{SO}_3(\text{g})$. (3)
- 7.3.6 The temperature is NOW increased and the reaction is allowed to reach equilibrium for the second time at the new temperature. On analysis of this new equilibrium mixture, it is found that 0,2 mole of $\text{SO}_3(\text{g})$ is present in the container.
- Calculate the equilibrium constant for this reaction at the new temperature. (8)

[21]

QUESTION 8 (Start on a new page.)

Learners conduct an investigation to determine which combination of two half-cells will provide the largest emf at standard conditions.

Three half-cells, represented as **A**, **B** and **C** in the table below, are available.

HALF-CELL A	HALF-CELL B	HALF-CELL C
Mg Mg ²⁺	Pb Pb ²⁺	Al Al ³⁺

The learners set up galvanic cells using different combinations of the above half-cells.

- 8.1 Write down the standard conditions under which these cells operate. (2)
- 8.2 Write down the dependent variable in this investigation. (1)
- 8.3 Use the Table of Standard Reduction Potentials to determine which ONE of the three half-cells (**A**, **B** or **C**) contains the:
- 8.3.1 Strongest reducing agent (1)
- 8.3.2 Strongest oxidising agent (1)
- 8.4 Without any calculation, write down the combination of two half-cells which will produce the highest emf. Write down only **AB**, **BC** or **AC**. (1)
- 8.5 One group of learners set up a galvanic cell using half-cells **A** and **B**, as shown below. **X** represents one of the components of the galvanic cell. (2)

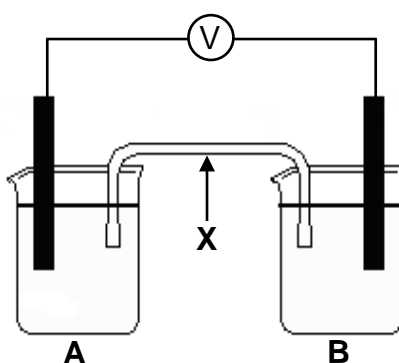

- 8.5.1 Write down the NAME or SYMBOL of the substance that will act as the anode in this cell. Give a reason for the answer. (2)
- 8.5.2 Calculate the initial emf of this cell. (4)
- 8.5.3 How will an increase in the concentration of the electrolyte in half-cell **B** affect the initial emf of the cell? Write down only INCREASES, DECREASES or REMAINS THE SAME. (2)
- 8.5.4 Briefly explain how component **X** ensures electrical neutrality while the cell is functioning. (2)

[16]

QUESTION 9 (Start on a new page.)

The simplified diagram below represents an electrochemical cell used in the refining of copper. One of the electrodes consists of impure copper and the other one of pure copper.

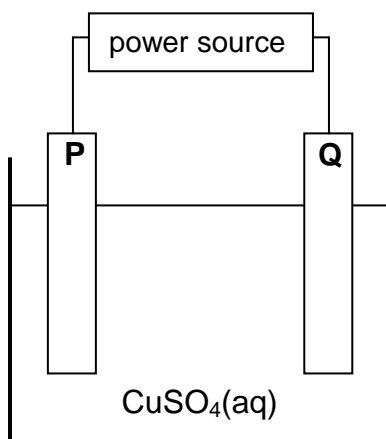

9.1 What type of power source is used to drive the reaction in this cell? Write down only AC or DC. (1)

9.2 Give a reason why the copper(II) sulphate is dissolved in water before it is used in this cell. (1)

When an electric current passes through the solution, electrode **P** becomes coated with copper.

9.3 Is electrode **P** the cathode or the anode? Support your answer by writing the half-reaction that takes place at electrode **P**. (3)

9.4 Write down the half-reaction that takes place at electrode **Q**. (2)

It is found that the impure copper plate contains platinum. The platinum forms a residue at the bottom of the container during electrolysis.

9.5 Refer to the relative strengths of reducing agents to explain why platinum forms a residue at the bottom of the container. (2)

9.6 How will the concentration of the copper(II) sulphate solution change during electrolysis? Write down only INCREASES, DECREASES or REMAINS THE SAME.

Give a reason for the answer. (3)

[12]

QUESTION 10 (Start on a new page.)

The simplified diagram of a cell used in the chlor-alkali industry is shown below.

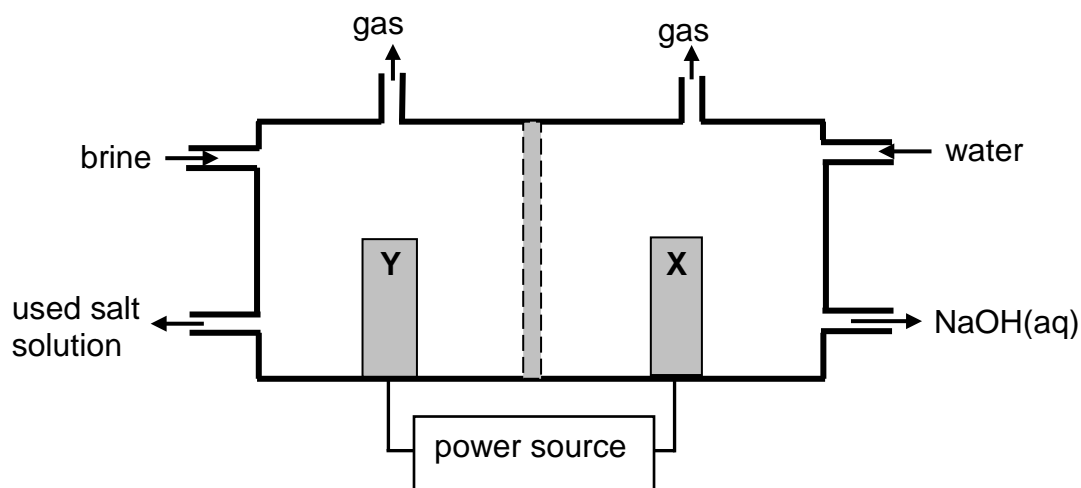

- 10.1 Write down the CHEMICAL FORMULA of brine. (1)
- 10.2 At which electrode, **X** or **Y**, is chlorine gas formed? (1)
- 10.3 Write down a half-reaction that explains the formation of hydrogen gas at one of the electrodes. (2)
- 10.4 The purity of the sodium hydroxide produced in the chlor-alkali industry depends on the extent to which it is separated from the chlorine gas produced by this cell. Briefly describe how chlorine gas and sodium hydroxide are prevented from mixing in this cell. (2)
- 10.5 Apart from advantages and disadvantages of products produced, write down for this process:
- 10.5.1 ONE positive impact on humans (2)
- 10.5.2 ONE negative impact on humans (2)

[10]

QUESTION 11 (Start on a new page.)

Mercury(II) oxide batteries are sometimes used in watches and cameras.

The two half-reactions involved in this battery and their respective reduction potentials are given below.

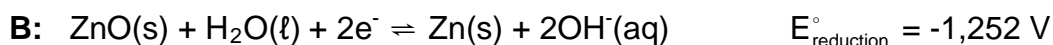
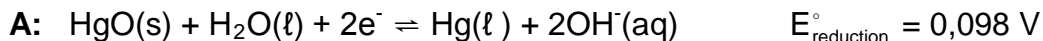

- 11.1 Which half-reaction (**A** or **B**) takes place at the cathode of this battery? Refer to the given reduction potentials and give a reason for the answer. (2)
- 11.2 Write down the net (overall) reaction that takes place in this battery. (3)
- 11.3 Write down the SYMBOL or FORMULA or NAME of the substance that acts as reducing agent in this battery.
Use oxidation numbers to explain the answer. (2)
- 11.4 State ONE safety concern regarding the disposal of these batteries. (2)

[9]

TOTAL SECTION B: 125
GRAND TOTAL: 150

**DATA FOR PHYSICAL SCIENCES GRADE 12
PAPER 2 (CHEMISTRY)**

**GEGEWENS VIR FISIESTE WETENSAPPE GRAAD 12
VRAESTEL 2 (CHEMIE)**

TABLE 1: PHYSICAL CONSTANTS/TABEL 1: FISIESTE KONSTANTES

NAME/NAAM	SYMBOL/SIMBOOL	VALUE/WAARDE
Standard pressure <i>Standaarddruk</i>	p^{θ}	$1,013 \times 10^5 \text{ Pa}$
Molar gas volume at STP <i>Molêre gasvolume by STD</i>	V_m	$22,4 \text{ dm}^3 \cdot \text{mol}^{-1}$
Standard temperature <i>Standaardtemperatuur</i>	T^{θ}	273 K
Charge on electron <i>Lading op elektron</i>	e	$-1,6 \times 10^{-19} \text{ C}$

TABLE 2: FORMULAE/TABEL 2: FORMULES

$n = \frac{m}{M}$	$c = \frac{n}{V}$ or/of $c = \frac{m}{MV}$
$q = I \Delta t$ $W = Vq$	$E_{\text{cell}}^{\theta} = E_{\text{cathode}}^{\theta} - E_{\text{anode}}^{\theta} / E_{\text{sel}}^{\theta} = E_{\text{katode}}^{\theta} - E_{\text{anode}}^{\theta}$ or/of $E_{\text{cell}}^{\theta} = E_{\text{reduction}}^{\theta} - E_{\text{oxidation}}^{\theta} / E_{\text{sel}}^{\theta} = E_{\text{reduksie}}^{\theta} - E_{\text{oksidasie}}^{\theta}$ or/of $E_{\text{cell}}^{\theta} = E_{\text{oxidising agent}}^{\theta} - E_{\text{reducing agent}}^{\theta} / E_{\text{sel}}^{\theta} = E_{\text{oksideermiddel}}^{\theta} - E_{\text{reduseermiddel}}^{\theta}$

NSC

TABLE 3: THE PERIODIC TABLE OF ELEMENTS
TABEL 3: DIE PERIODIEKE TABEL VAN ELEMENTE

1 (I)	2 (II)	3	4	5	6	7	8	9	10	11	12	13 (III)	14 (IV)	15 (V)	16 (VI)	17 (VII)	18 (VIII)
1 2,1 H																	2 He 4
3 1,0 Li	4 1,5 Be											5 2,0 B	6 2,5 C	7 3,0 N	8 3,5 O	9 4,0 F	10 20 Ne
11 0,9 Na	12 1,2 Mg											13 1,5 Al	14 1,8 Si	15 2,1 P	16 2,5 S	17 3,0 Cl	18 40 Ar
19 0,8 K	20 1,0 Ca	21 1,3 Sc	22 1,5 Ti	23 1,6 V	24 1,6 Cr	25 1,5 Mn	26 1,8 Fe	27 1,8 Co	28 1,8 Ni	29 1,9 Cu	30 1,6 Zn	31 1,6 Ga	32 1,8 Ge	33 2,0 As	34 2,4 Se	35 2,8 Br	36 84 Kr
37 0,8 Rb	38 1,0 Sr	39 1,2 Y	40 1,4 Zr	41 1,6 Nb	42 1,8 Mo	43 1,9 Tc	44 2,2 Ru	45 2,2 Rh	46 2,2 Pd	47 1,9 Ag	48 1,7 Cd	49 1,7 In	50 1,8 Sn	51 1,9 Sb	52 2,1 Te	53 2,5 I	54 131 Xe
55 0,7 Cs	56 0,9 Ba	57 139 La	72 1,6 Hf	73 181 Ta	74 184 W	75 186 Re	76 190 Os	77 192 Ir	78 195 Pt	79 197 Au	80 201 Hg	81 1,8 Tl	82 1,8 Pb	83 1,9 Bi	84 2,0 Po	85 2,5 At	86 86 Rn
87 0,7 Fr	88 0,9 Ra 226	89 Ac															
			58 Ce 140	59 Pr 141	60 Nd 144	61 Pm	62 Sm 150	63 Eu 152	64 Gd 157	65 Tb 159	66 Dy 163	67 Ho 165	68 Er 167	69 Tm 169	70 Yb 173	71 Lu 175	
			90 Th 232	91 Pa	92 U 238	93 Np	94 Pu	95 Am	96 Cm	97 Bk	98 Cf	99 Es	100 Fm	101 Md	102 No	103 Lr	

KEY/SLEUTEL

Atomic number
Atoomgetal

Electronegativity
Elektronegatiwiteit

29 Cu 63,5

Symbol
Simbool

Approximate relative atomic mass
Benaderde relatiewe atoommassa

TABLE 4A: STANDARD REDUCTION POTENTIALS
TABEL 4A: STANDAARD-REDUKSIEPOTENSIALE

Half-reactions/ <i>Halfreaksies</i>	E^{\ominus} (V)
$F_2(g) + 2e^- \rightleftharpoons 2F^-$	+ 2,87
$Co^{3+} + e^- \rightleftharpoons Co^{2+}$	+ 1,81
$H_2O_2 + 2H^+ + 2e^- \rightleftharpoons 2H_2O$	+1,77
$MnO_4^- + 8H^+ + 5e^- \rightleftharpoons Mn^{2+} + 4H_2O$	+ 1,51
$Cl_2(g) + 2e^- \rightleftharpoons 2Cl^-$	+ 1,36
$Cr_2O_7^{2-} + 14H^+ + 6e^- \rightleftharpoons 2Cr^{3+} + 7H_2O$	+ 1,33
$O_2(g) + 4H^+ + 4e^- \rightleftharpoons 2H_2O$	+ 1,23
$MnO_2 + 4H^+ + 2e^- \rightleftharpoons Mn^{2+} + 2H_2O$	+ 1,23
$Pt^{2+} + 2e^- \rightleftharpoons Pt$	+ 1,20
$Br_2(l) + 2e^- \rightleftharpoons 2Br^-$	+ 1,07
$NO_3^- + 4H^+ + 3e^- \rightleftharpoons NO(g) + 2H_2O$	+ 0,96
$Hg^{2+} + 2e^- \rightleftharpoons Hg(l)$	+ 0,85
$Ag^+ + e^- \rightleftharpoons Ag$	+ 0,80
$NO_3^- + 2H^+ + e^- \rightleftharpoons NO_2(g) + H_2O$	+ 0,80
$Fe^{3+} + e^- \rightleftharpoons Fe^{2+}$	+ 0,77
$O_2(g) + 2H^+ + 2e^- \rightleftharpoons H_2O_2$	+ 0,68
$I_2 + 2e^- \rightleftharpoons 2I^-$	+ 0,54
$Cu^+ + e^- \rightleftharpoons Cu$	+ 0,52
$SO_2 + 4H^+ + 4e^- \rightleftharpoons S + 2H_2O$	+ 0,45
$2H_2O + O_2 + 4e^- \rightleftharpoons 4OH^-$	+ 0,40
$Cu^{2+} + 2e^- \rightleftharpoons Cu$	+ 0,34
$SO_4^{2-} + 4H^+ + 2e^- \rightleftharpoons SO_2(g) + 2H_2O$	+ 0,17
$Cu^{2+} + e^- \rightleftharpoons Cu^+$	+ 0,16
$Sn^{4+} + 2e^- \rightleftharpoons Sn^{2+}$	+ 0,15
$S + 2H^+ + 2e^- \rightleftharpoons H_2S(g)$	+ 0,14
$2H^+ + 2e^- \rightleftharpoons H_2(g)$	0,00
$Fe^{3+} + 3e^- \rightleftharpoons Fe$	- 0,06
$Pb^{2+} + 2e^- \rightleftharpoons Pb$	- 0,13
$Sn^{2+} + 2e^- \rightleftharpoons Sn$	- 0,14
$Ni^{2+} + 2e^- \rightleftharpoons Ni$	- 0,27
$Co^{2+} + 2e^- \rightleftharpoons Co$	- 0,28
$Cd^{2+} + 2e^- \rightleftharpoons Cd$	- 0,40
$Cr^{3+} + e^- \rightleftharpoons Cr^{2+}$	- 0,41
$Fe^{2+} + 2e^- \rightleftharpoons Fe$	- 0,44
$Cr^{3+} + 3e^- \rightleftharpoons Cr$	- 0,74
$Zn^{2+} + 2e^- \rightleftharpoons Zn$	- 0,76
$2H_2O + 2e^- \rightleftharpoons H_2(g) + 2OH^-$	- 0,83
$Cr^{2+} + 2e^- \rightleftharpoons Cr$	- 0,91
$Mn^{2+} + 2e^- \rightleftharpoons Mn$	- 1,18
$Al^{3+} + 3e^- \rightleftharpoons Al$	- 1,66
$Mg^{2+} + 2e^- \rightleftharpoons Mg$	- 2,36
$Na^+ + e^- \rightleftharpoons Na$	- 2,71
$Ca^{2+} + 2e^- \rightleftharpoons Ca$	- 2,87
$Sr^{2+} + 2e^- \rightleftharpoons Sr$	- 2,89
$Ba^{2+} + 2e^- \rightleftharpoons Ba$	- 2,90
$Cs^+ + e^- \rightleftharpoons Cs$	- 2,92
$K^+ + e^- \rightleftharpoons K$	- 2,93
$Li^+ + e^- \rightleftharpoons Li$	- 3,05

Increasing oxidising ability/*Toenemende oksiderende vermoë*

Increasing reducing ability/*Toenemende reduserende vermoë*

NSC

TABLE 4B: STANDARD REDUCTION POTENTIALS
TABEL 4B: STANDAARD-REDUKSIEPOTENSIALE

Half-reactions/ <i>Halfreaksies</i>	E^{\ominus} (V)
$\text{Li}^+ + e^- \rightleftharpoons \text{Li}$	-3,05
$\text{K}^+ + e^- \rightleftharpoons \text{K}$	-2,93
$\text{Cs}^+ + e^- \rightleftharpoons \text{Cs}$	-2,92
$\text{Ba}^{2+} + 2e^- \rightleftharpoons \text{Ba}$	-2,90
$\text{Sr}^{2+} + 2e^- \rightleftharpoons \text{Sr}$	-2,89
$\text{Ca}^{2+} + 2e^- \rightleftharpoons \text{Ca}$	-2,87
$\text{Na}^+ + e^- \rightleftharpoons \text{Na}$	-2,71
$\text{Mg}^{2+} + 2e^- \rightleftharpoons \text{Mg}$	-2,36
$\text{Al}^{3+} + 3e^- \rightleftharpoons \text{Al}$	-1,66
$\text{Mn}^{2+} + 2e^- \rightleftharpoons \text{Mn}$	-1,18
$\text{Cr}^{2+} + 2e^- \rightleftharpoons \text{Cr}$	-0,91
$2\text{H}_2\text{O} + 2e^- \rightleftharpoons \text{H}_2(\text{g}) + 2\text{OH}^-$	-0,83
$\text{Zn}^{2+} + 2e^- \rightleftharpoons \text{Zn}$	-0,76
$\text{Cr}^{3+} + 3e^- \rightleftharpoons \text{Cr}$	-0,74
$\text{Fe}^{2+} + 2e^- \rightleftharpoons \text{Fe}$	-0,44
$\text{Cr}^{3+} + e^- \rightleftharpoons \text{Cr}^{2+}$	-0,41
$\text{Cd}^{2+} + 2e^- \rightleftharpoons \text{Cd}$	-0,40
$\text{Co}^{2+} + 2e^- \rightleftharpoons \text{Co}$	-0,28
$\text{Ni}^{2+} + 2e^- \rightleftharpoons \text{Ni}$	-0,27
$\text{Sn}^{2+} + 2e^- \rightleftharpoons \text{Sn}$	-0,14
$\text{Pb}^{2+} + 2e^- \rightleftharpoons \text{Pb}$	-0,13
$\text{Fe}^{3+} + 3e^- \rightleftharpoons \text{Fe}$	-0,06
$2\text{H}^+ + 2e^- \rightleftharpoons \text{H}_2(\text{g})$	0,00
$\text{S} + 2\text{H}^+ + 2e^- \rightleftharpoons \text{H}_2\text{S}(\text{g})$	+0,14
$\text{Sn}^{4+} + 2e^- \rightleftharpoons \text{Sn}^{2+}$	+0,15
$\text{Cu}^{2+} + e^- \rightleftharpoons \text{Cu}^+$	+0,16
$\text{SO}_4^{2-} + 4\text{H}^+ + 2e^- \rightleftharpoons \text{SO}_2(\text{g}) + 2\text{H}_2\text{O}$	+0,17
$\text{Cu}^{2+} + 2e^- \rightleftharpoons \text{Cu}$	+0,34
$2\text{H}_2\text{O} + \text{O}_2 + 4e^- \rightleftharpoons 4\text{OH}^-$	+0,40
$\text{SO}_2 + 4\text{H}^+ + 4e^- \rightleftharpoons \text{S} + 2\text{H}_2\text{O}$	+0,45
$\text{Cu}^+ + e^- \rightleftharpoons \text{Cu}$	+0,52
$\text{I}_2 + 2e^- \rightleftharpoons 2\text{I}^-$	+0,54
$\text{O}_2(\text{g}) + 2\text{H}^+ + 2e^- \rightleftharpoons \text{H}_2\text{O}_2$	+0,68
$\text{Fe}^{3+} + e^- \rightleftharpoons \text{Fe}^{2+}$	+0,77
$\text{NO}_3^- + 2\text{H}^+ + e^- \rightleftharpoons \text{NO}_2(\text{g}) + \text{H}_2\text{O}$	+0,80
$\text{Ag}^+ + e^- \rightleftharpoons \text{Ag}$	+0,80
$\text{Hg}^{2+} + 2e^- \rightleftharpoons \text{Hg}(\ell)$	+0,85
$\text{NO}_3^- + 4\text{H}^+ + 3e^- \rightleftharpoons \text{NO}(\text{g}) + 2\text{H}_2\text{O}$	+0,96
$\text{Br}_2(\ell) + 2e^- \rightleftharpoons 2\text{Br}^-$	+1,07
$\text{Pt}^{2+} + 2e^- \rightleftharpoons \text{Pt}$	+1,20
$\text{MnO}_2 + 4\text{H}^+ + 2e^- \rightleftharpoons \text{Mn}^{2+} + 2\text{H}_2\text{O}$	+1,23
$\text{O}_2(\text{g}) + 4\text{H}^+ + 4e^- \rightleftharpoons 2\text{H}_2\text{O}$	+1,23
$\text{Cr}_2\text{O}_7^{2-} + 14\text{H}^+ + 6e^- \rightleftharpoons 2\text{Cr}^{3+} + 7\text{H}_2\text{O}$	+1,33
$\text{Cl}_2(\text{g}) + 2e^- \rightleftharpoons 2\text{Cl}^-$	+1,36
$\text{MnO}_4^- + 8\text{H}^+ + 5e^- \rightleftharpoons \text{Mn}^{2+} + 4\text{H}_2\text{O}$	+1,51
$\text{H}_2\text{O}_2 + 2\text{H}^+ + 2e^- \rightleftharpoons 2\text{H}_2\text{O}$	+1,77
$\text{Co}^{3+} + e^- \rightleftharpoons \text{Co}^{2+}$	+1,81
$\text{F}_2(\text{g}) + 2e^- \rightleftharpoons 2\text{F}^-$	+2,87

Increasing oxidising ability/*Toenemende oksiderende vermoë*

Increasing reducing ability/*Toenemende reduserende vermoë*